

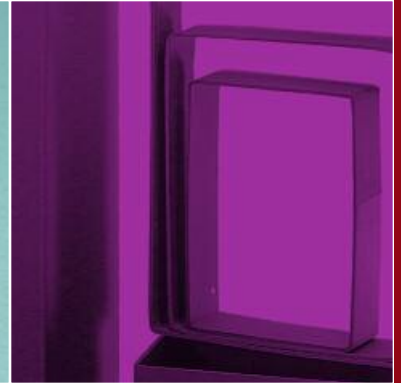

# SHAPES UNLIMITED <sup>INC</sup>

Giving shape to your ideas.

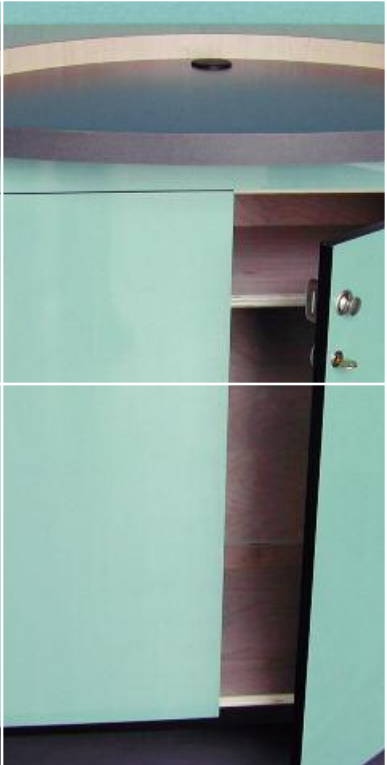

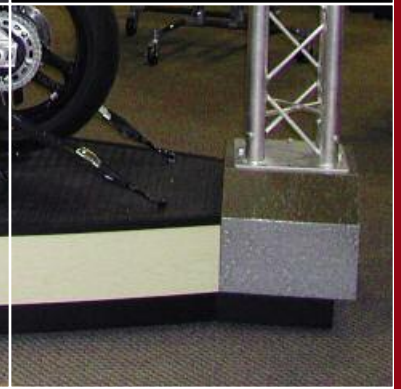

# FABRICATION SERVICES

-When time and money matters-

Thank you for your interest in **Shapes Unlimited!** We have been helping the Powersports industry design, merchandise, and manufacture fixtures for several years. We have the experience and expertise to help you on your next project, no matter how big or small.

**Shapes Unlimited** specializes in the production of store fixtures, counters, and product displays. You may select from our stock fixture line or have a custom component designed to fit your specific requirements. If your project also requires glass cases, trusses, slatwall or any merchandising accessories, we carry the inventory to turn your project quickly. Several photos of our custom counters and standard store fixtures are available for viewing at [www.shapesunlimited.com](http://www.shapesunlimited.com).

**Shapes Unlimited** has the experience and qualifications to take you and your dealership to the next level. Our designs/store layout ideas and services, quality fixtures, strong customer service, and attention to detail have always been key to our success. By selecting our team to coordinate your next remodel project, you can be assured of future successes for several years to come.



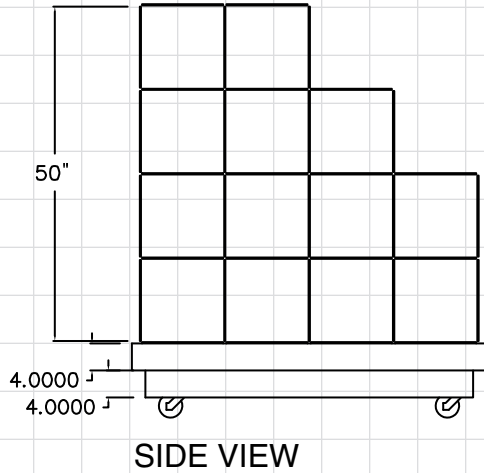

## MODEL KA-48 GLASS DISPLAY UNIT, STEPPED

- 26 modules: 12"W x 14"D x 12"H – all with connectors
- $3/16$ " tempered safety glass
- 30.5"W x 52.5"L x 8"H base with casters
- Top and sides covered with laminate

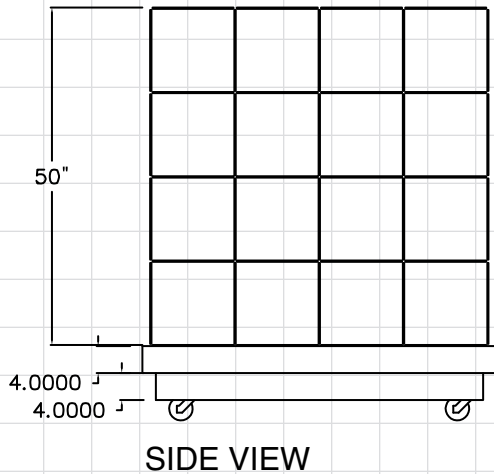
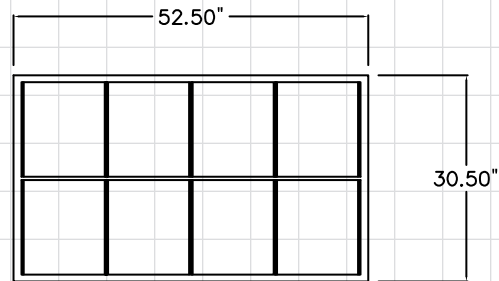

## MODEL KD-48 GLASS CUBE UNIT, FULL

- 32 modules: 12"W x 14"D x 12"H – all with connectors
- $3/16$ " tempered safety glass
- 30.5"W x 52.5"L x 8"H base with casters
- Top and sides covered with laminate

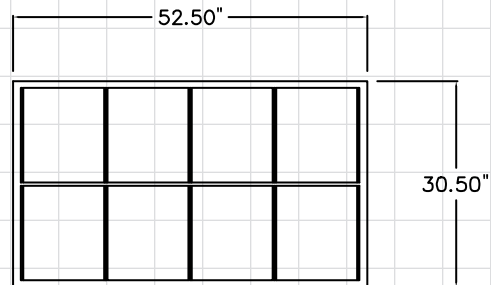

**Giving  
Shape  
To Your  
Ideas.**

**MODEL KE-48**  
**GLASS CUBE UNIT, 4-WAY**

- 16 modules: 12"W x 14"D x 12"H – all with connectors
- $3/16$ " tempered safety glass
- 29.5"W x 29.5"L x 8"H base with casters
- Top and sides covered with laminate

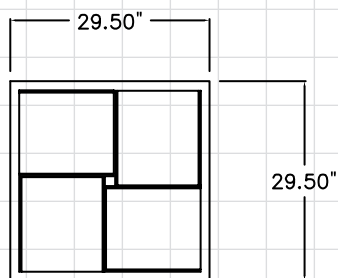

PLAN VIEW

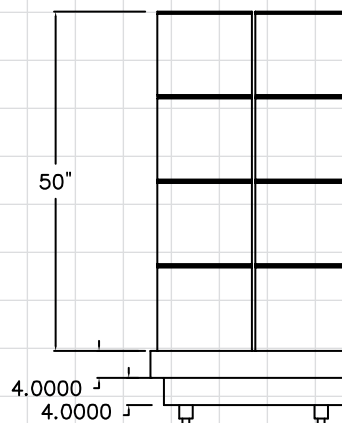

SIDE VIEW

**MODEL KB-48**  
**GLASS DISPLAYER UNIT, SQUARE**

- 16 modules: 12"W x 14"D x 12"H – all with connectors
- $3/16$ " tempered safety glass
- 30.5"W x 27.5"L x 8"H base with casters
- Top and sides covered with laminate

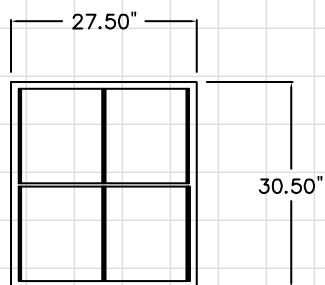

PLAN VIEW

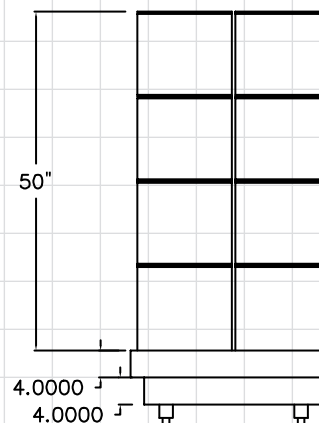

SIDE VIEW

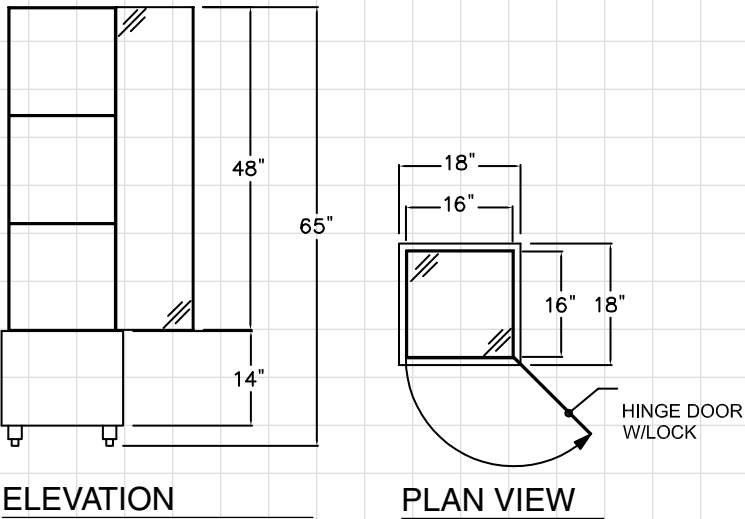

**MODEL KC-48**  
**GLASS TOWER UNIT**

- Modules: 16"W x 16"D x 48"H
- <sup>3</sup>/<sub>16</sub>" tempered safety glass
- 2 adjustable shelves, connectors, hinges and locks
- 18"W x 18"L x 14"H base with casters
- Top and sides covered with laminate

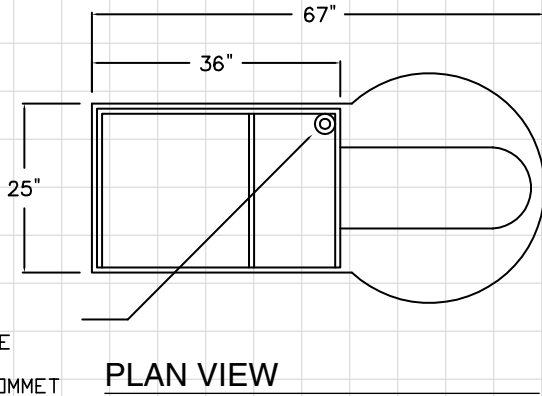

**MODEL PCK-42 (#1)**  
**PARTS POD KIOSK W/DOORS**

- .75" construction
- Double doors and interior adjustable shelves
- Melamine interior
- Entire unit covered with laminate

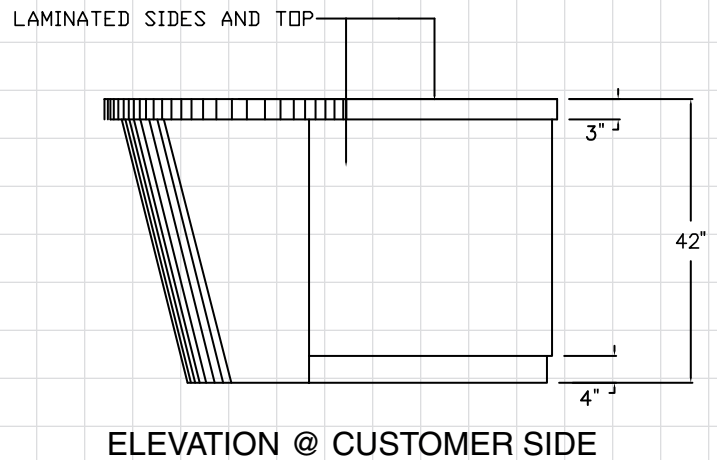
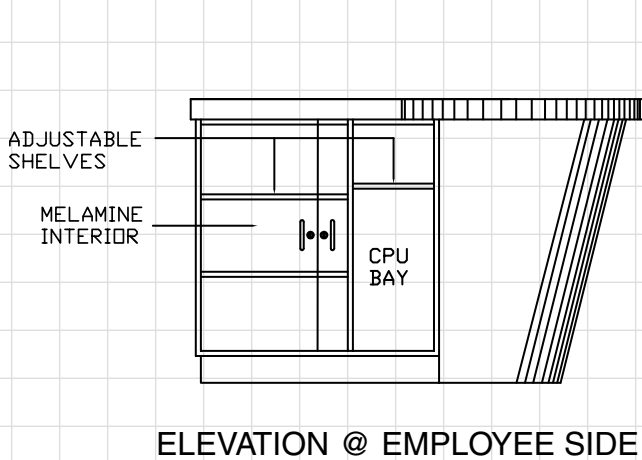

**Giving  
Shape  
To Your  
Ideas.**

**MODEL KRC-48  
GLASS TOWER UNIT, RADIUS**

- Modules: 16"W x 16"D x 48"H
- <sup>3</sup>/<sub>16</sub>" tempered safety glass
- 2 adjustable shelves, connectors, hinges and locks
- 20"W x 20"L x 14"H radiused base with casters
- Top and sides covered with laminate

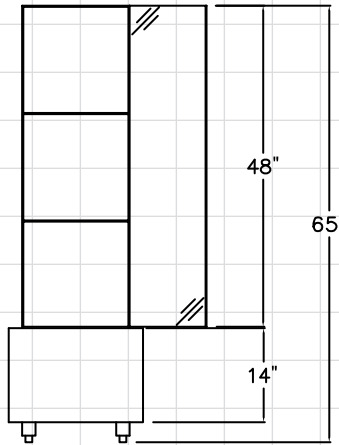

**PLAN VIEW**

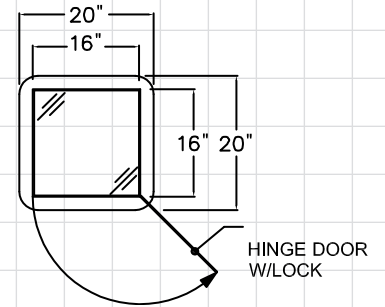

**ELEVATION**

**MODEL PCK-42 (#2)  
PARTS POD KIOSK W/DRAWER**

- .75" construction
- One locking drawer and adjustable shelf
- Melamine interior
- Entire unit covered with laminate

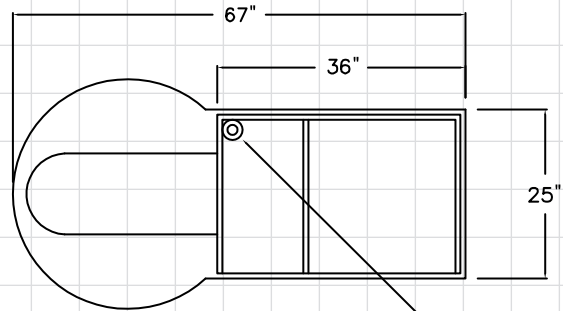

**PLAN VIEW**

ELECTRICAL  
ACCESS HOLE  
WITH BLACK  
PLASTIC GROMMET

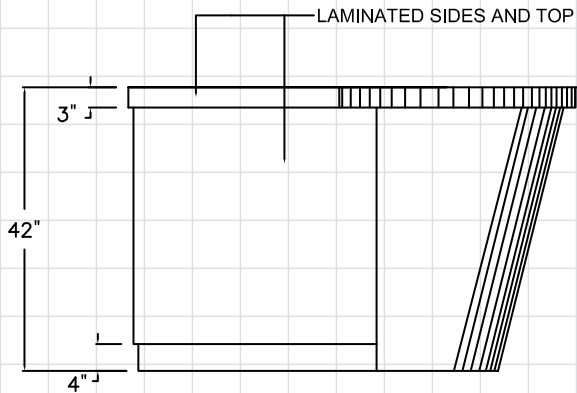

**ELEVATION @ CUSTOMER SIDE**

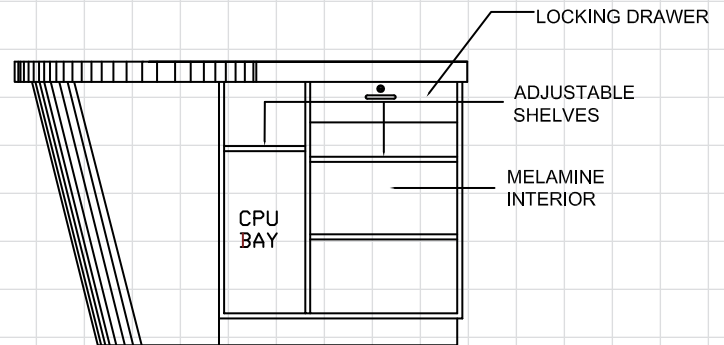

**ELEVATION @ EMPLOYEE SIDE**

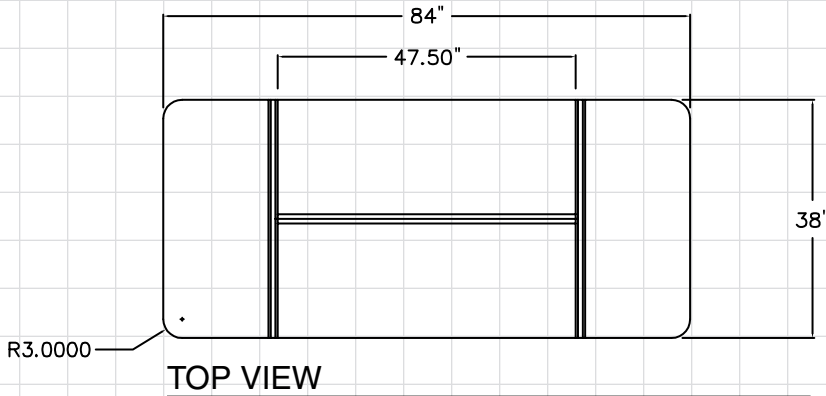

**MODEL SW-H**  
**SLATWALL DISPLAYER, "H"**

- .75" particleboard tops and bottoms
- Casters to spec
- Covered slatwall with black aluminum inserts
- Trim painted black
- Sides and top covered with laminate

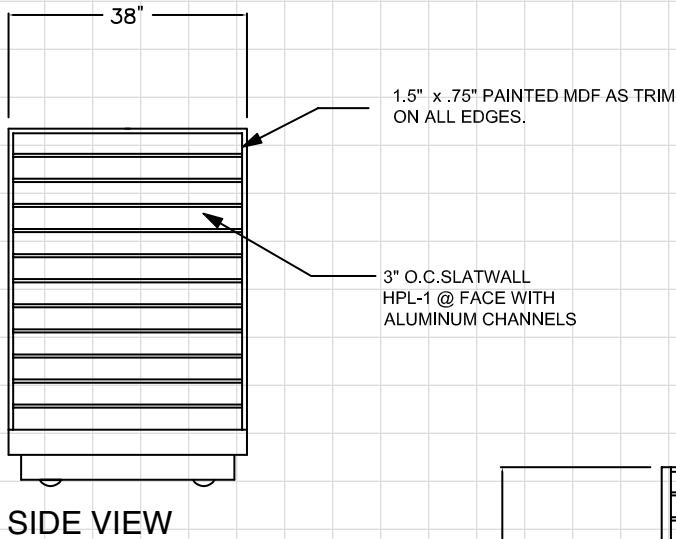

**MODEL H-HK**  
**"H" HARDWARE KIT**

- (4) - 12" x 47" x .75" black shelves
- (2) - 12" x 34" x .75" black shelves
- (12) - 12" shelf knife brackets
- (12) - 4" hooks
- (12) - 6" hooks

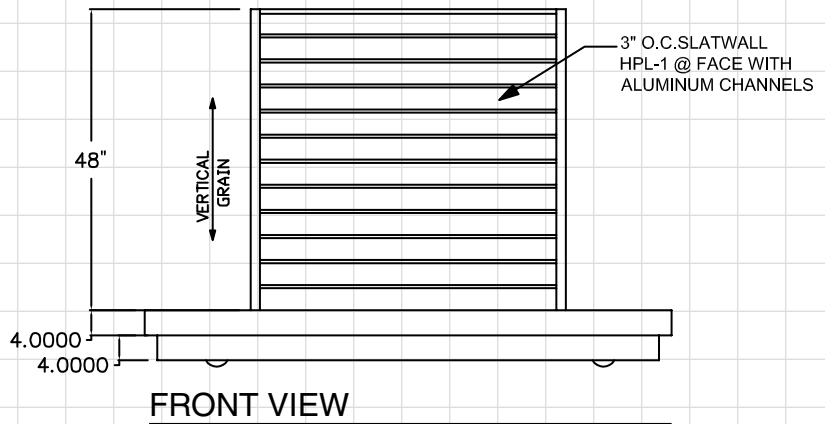



**Giving  
Shape  
To Your  
Ideas.**

### MODEL SW-36

#### SLATWALL DISPLAYER, "4-WAY"

- .75" particleboard tops and bottoms
- Casters to spec
- Laminate covered slatwall with vinyl inserts
- Trim painted black
- Sides and top covered with laminate

### MODEL SW-HK

#### "4-WAY" HARDWARE KIT

- (8) - 12" x 18" x .75" black shelves
- (16) - 12" shelf knife brackets
- (6) - 4" hooks
- (6) - 8" hooks
- (6) - 12" hooks

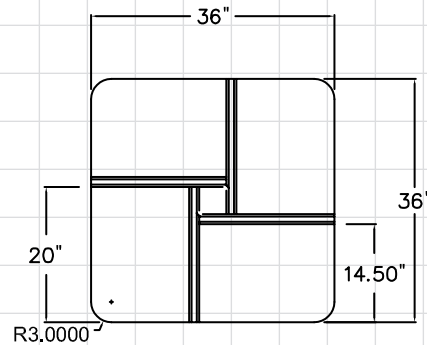

PLAN VIEW

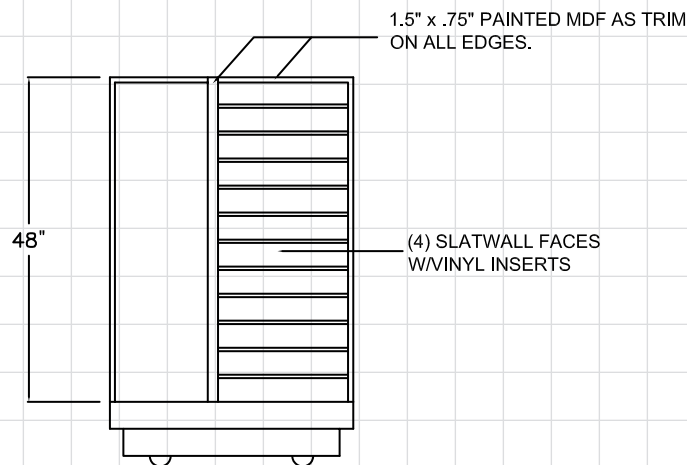

ELEVATION

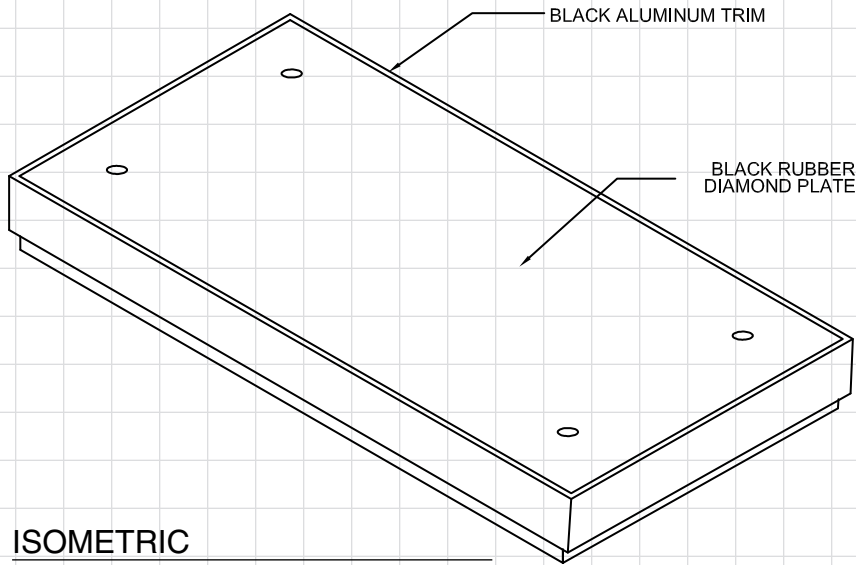

ISOMETRIC

**MODEL G-12**  
**MODEL G-18**  
**MODEL G-24**

## SQUARE MOTORCYCLE PLATFORMS

- Square corners
- .75" ply construction and interior ribbing
- Heavy duty casters and tie downs
- Top covered with black rubber diamond plate
- Top edge trimmed with 1" x 1" black aluminum
- Sides and kick covered with laminate

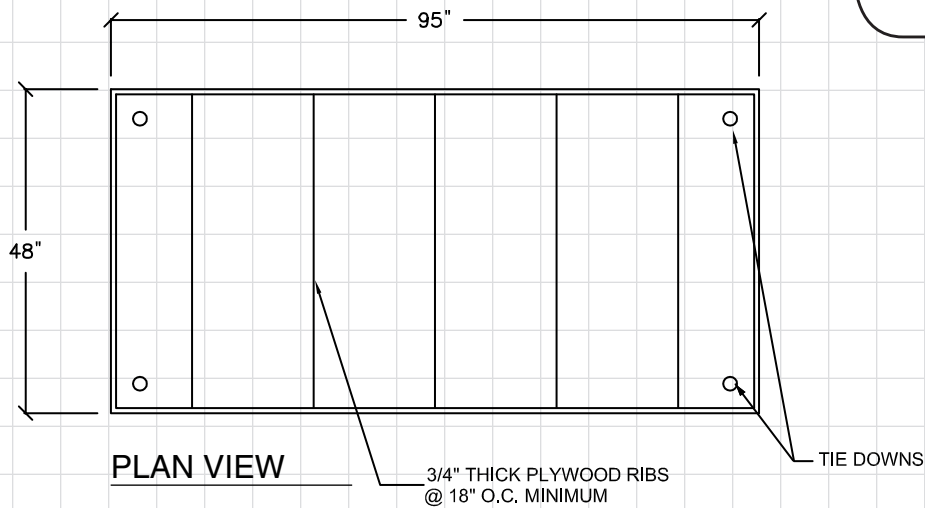

PLAN VIEW

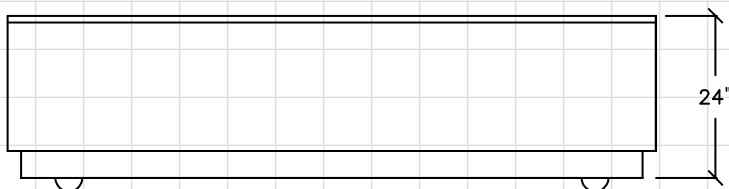
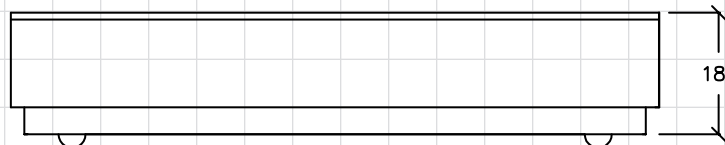
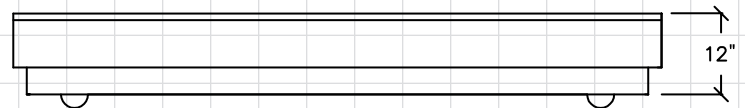

ELEVATION

**Giving  
Shape  
To Your  
Ideas.**

**MODEL R-12  
MODEL R-18  
MODEL R-24**

**RADIUS MOTORCYCLE  
PLATFORMS**

- .75" ply construction and interior ribbing
- .375" bending ply sides
- Heavy duty casters and tie downs
- Top covered with black rubber diamond plate
- Top edge trimmed with 1" x 1" black aluminum
- Sides and kick covered with laminate

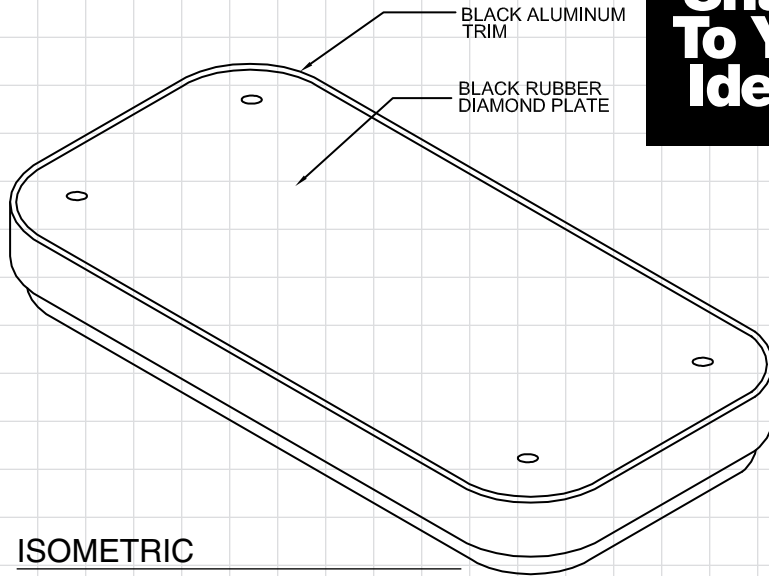

**ISOMETRIC**

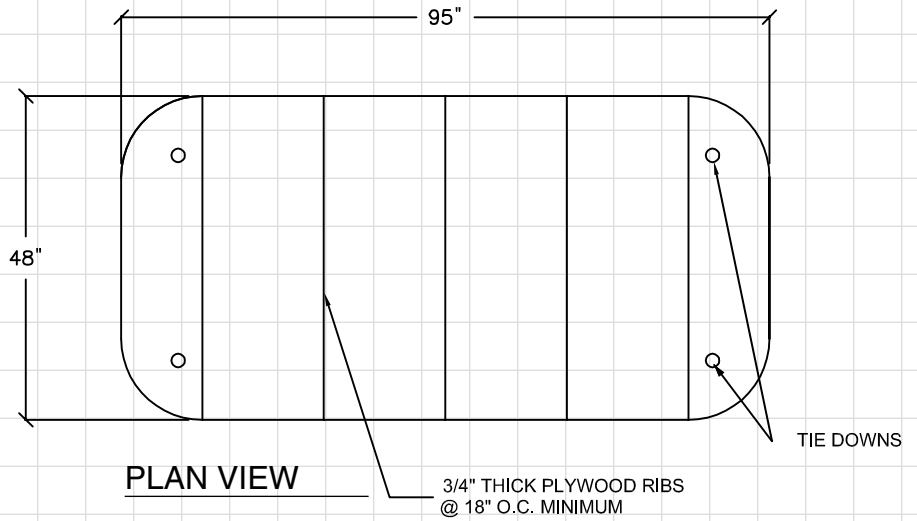

**PLAN VIEW**

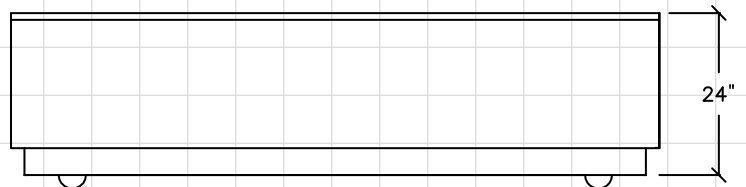
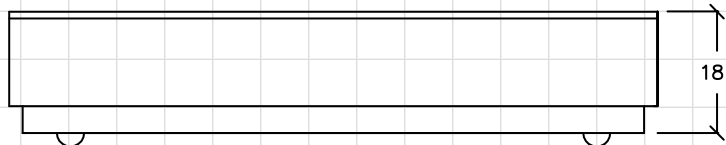
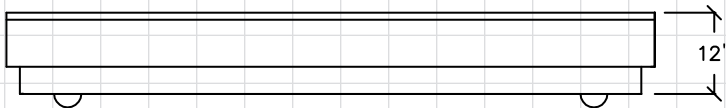

**ELEVATION**

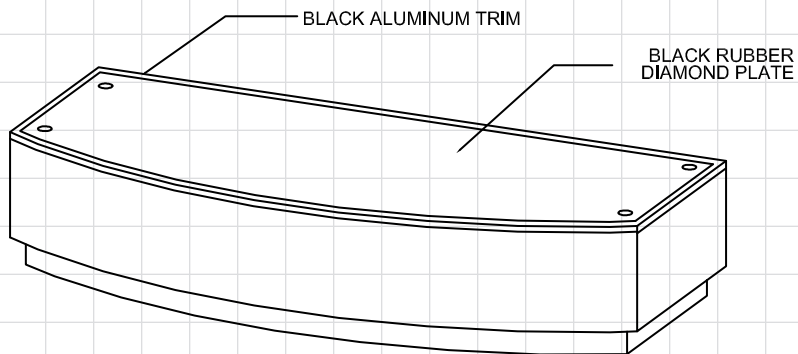

ISOMETRIC

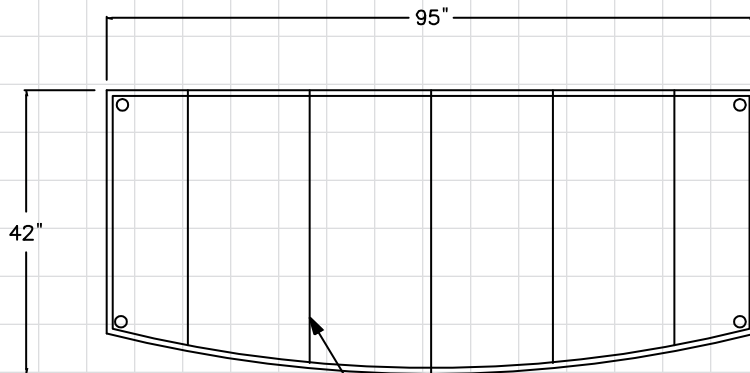

PLAN VIEW

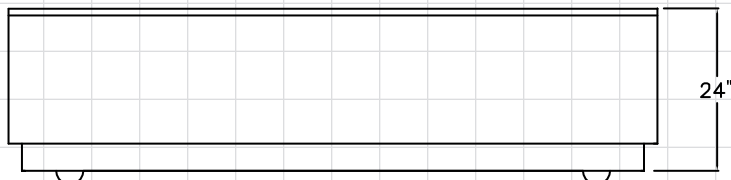
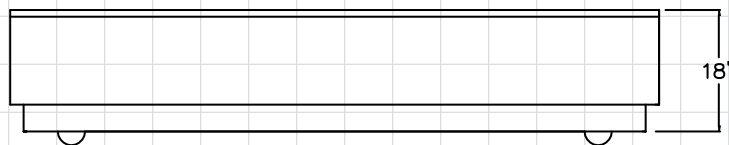
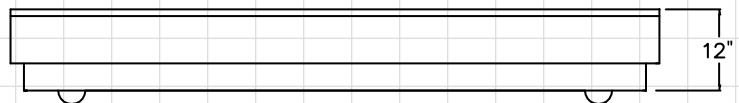

ELEVATION

**MODEL D-12**  
**MODEL D-18**  
**MODEL D-24**

**"D" MOTORCYCLE PLATFORMS**

- Square corners
- .75" ply construction and interior ribbing
- Heavy duty casters and tie downs
- Top covered with black rubber diamond plate
- Top edge trimmed with 1" x 1" black aluminum
- Sides and kick covered with laminate

**Giving  
Shape  
To Your  
Ideas.**

**MODEL O-12  
MODEL O-18  
MODEL O-24**

**OVAL MOTORCYCLE  
PLATFORMS**

- .75" ply construction and interior ribbing
- .375" bending ply sides
- Heavy duty casters and tie downs
- Top covered with black rubber diamond plate
- Sides and kick covered with laminate

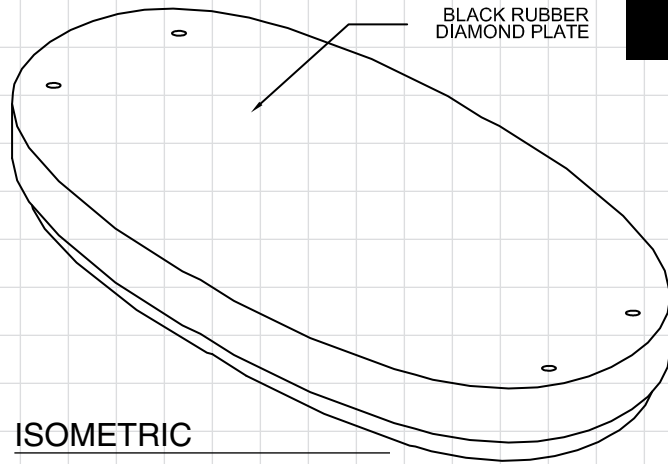

**ISOMETRIC**

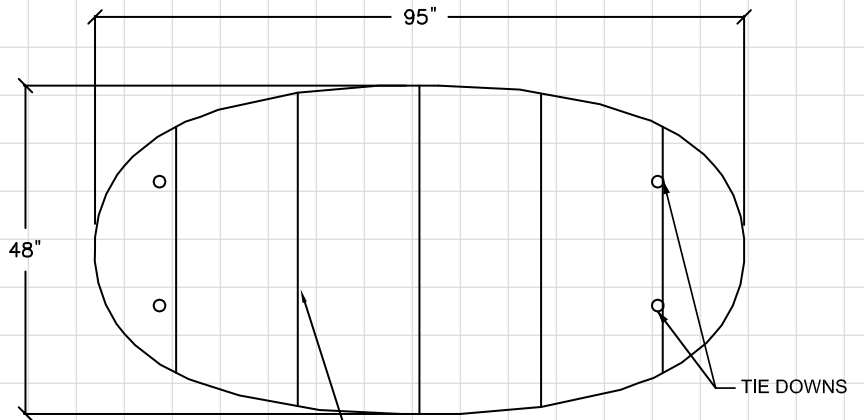

**PLAN VIEW**

3/4" THICK PLYWOOD RIBS @ 18" O.C. MINIMUM

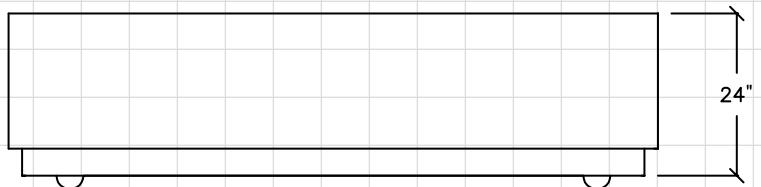
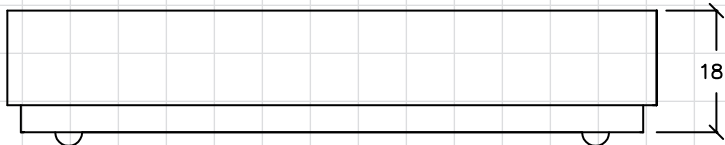
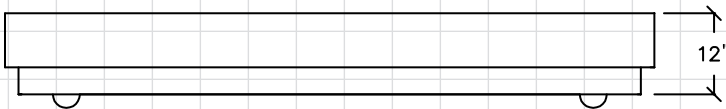

**ELEVATION**

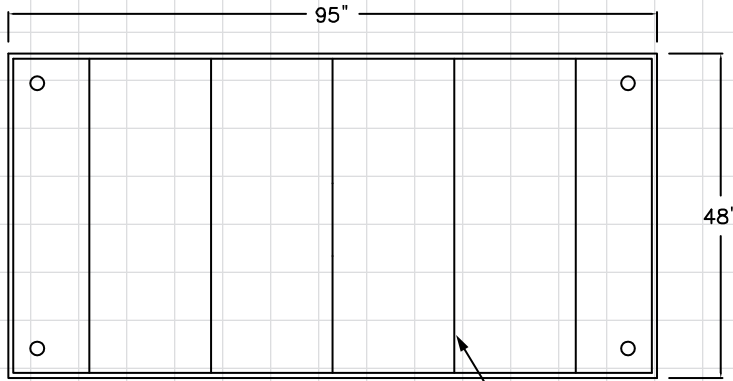

PLAN VIEW

3/4" THICK PLYWOOD RIBS @ 18" O.C. MINIMUM

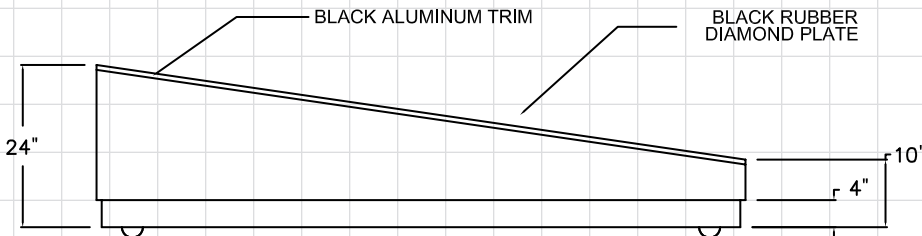

ELEVATION

## MODEL H-24

### SLANT MOTORCYCLE PLATFORM

- Square corners
- .75" ply construction and interior ribbing
- Heavy duty casters and tie downs
- Top covered with black rubber diamond plate
- Top edge trimmed with 1" x 1" black aluminum
- Sides and kick covered with laminate

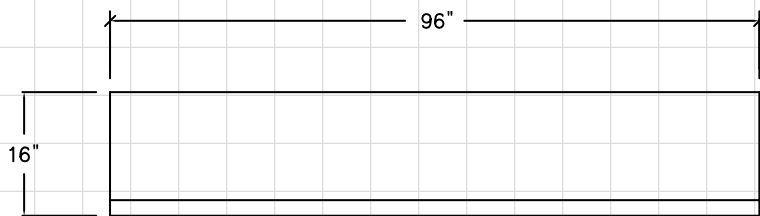

PLAN VIEW

## MODEL BD-96

### BASE DECKS

- .75" MDF construction with 4" toe kick
- Top, face and sides covered with laminate

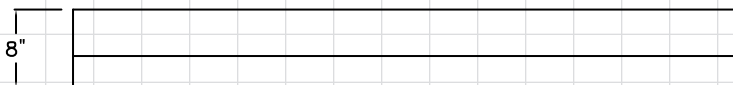

ELEVATION

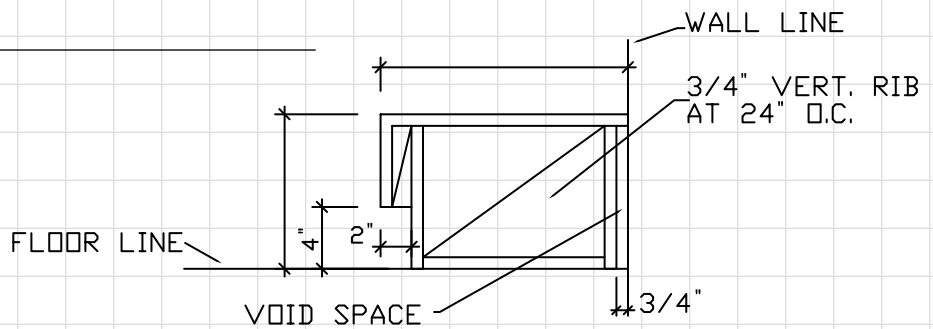

SECTION

**Giving  
Shape  
To Your  
Ideas.**

**MODEL T-30  
SALES TABLE**

- 18" x 18" x 29" square with 3" radius corners
- 75" particleboard top and bottom
- 42" x 1" table top
- Top and sides covered with laminate
- Optional – .38" glass top not included

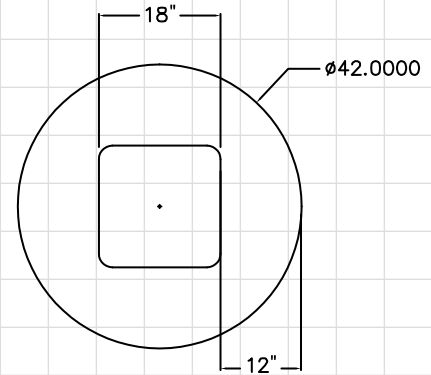
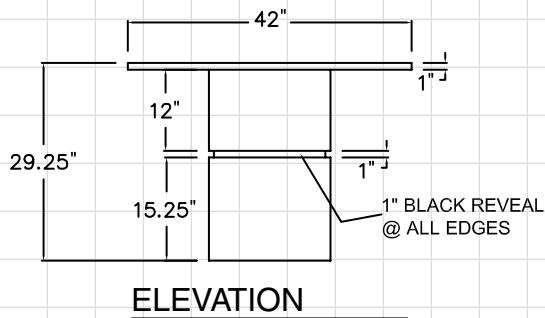

**MODEL T-18  
COFFEE TABLE**

- 18" x 18" x 18" square with 3" radius corners
- .75" particleboard top and bottom
- 42" x 1" table top
- Top and sides covered with laminate
- Optional – .38" glass top not included

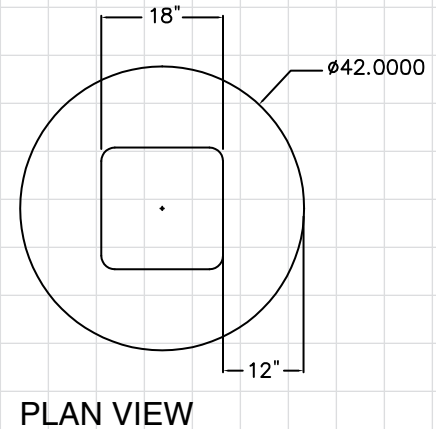
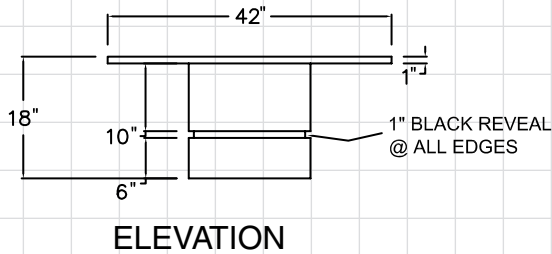



## MODEL CASH-108 CASHIER COUNTER

- Black melamine interior
- Optional cash drawer
- Radiused cash register guard
- Black grommet holes
- Adjustable shelving with CPU computer bay
- Exterior surfaces covered with high pressure laminate per finish schedule
- Decorative metal pucks

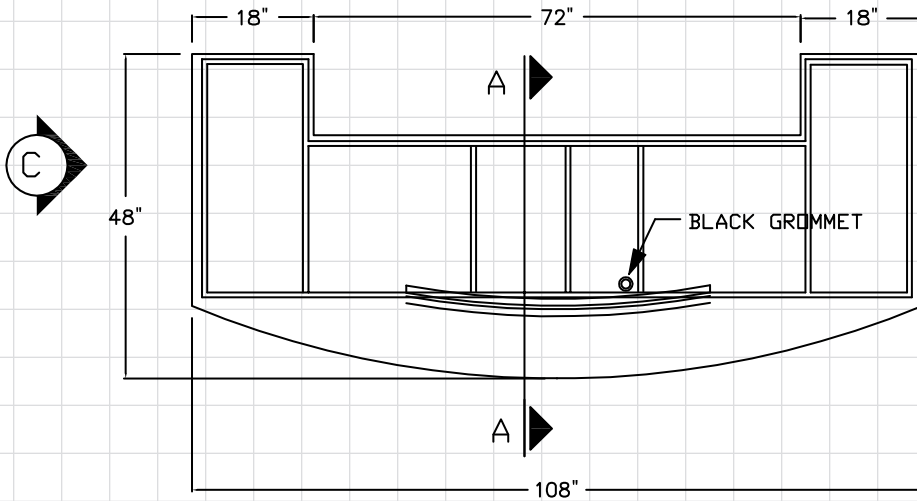

PLAN VIEW

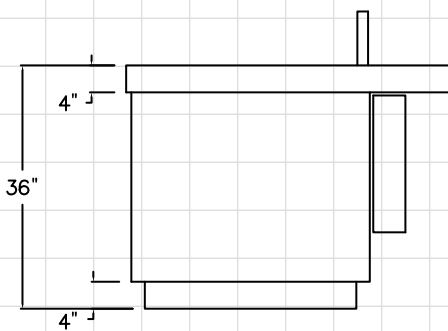

SECTION A-A

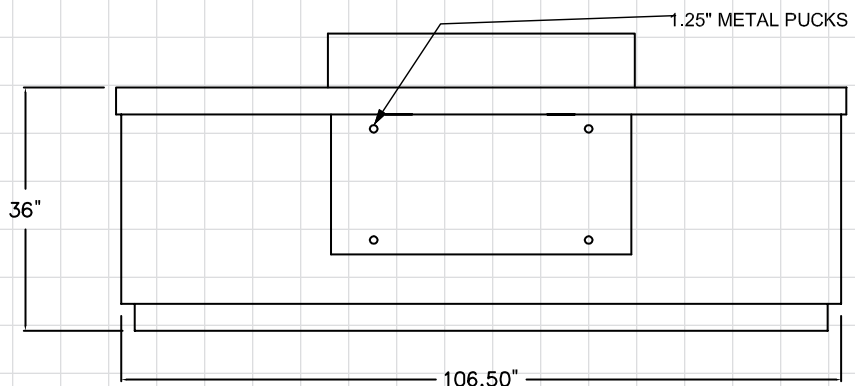

FRONT ELEVATION

3/4" THICK PLYWOOD/MDF CONSTRUCTION. FINISH ALL EXPOSED SURFACES.

ADJUSTABLE SHELVES

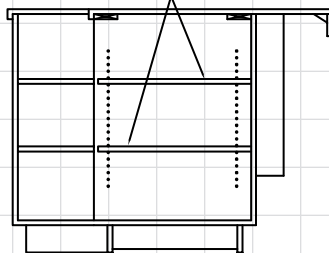

SIDE ELEVATION

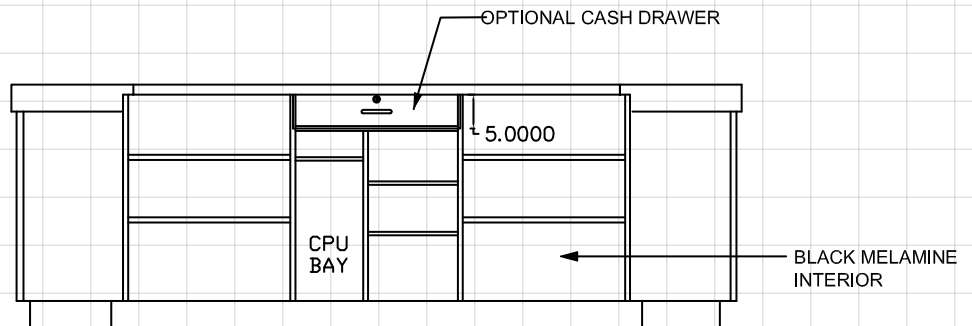

REAR ELEVATION





**Giving  
Shape  
To Your  
Ideas.**

**MODEL SV-96  
SERVICE COUNTER**

- Black melamine interior
- Black grommet holes
- File drawers
- Adjustable shelving with CPU computer bays
- Exterior surfaces covered with high pressure laminate per finish schedule

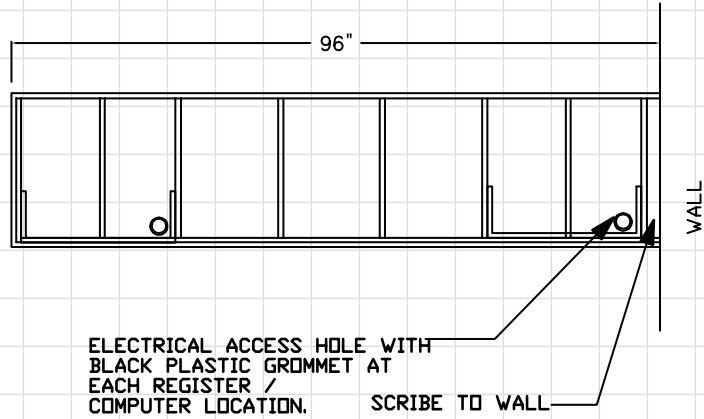

**PLAN VIEW**

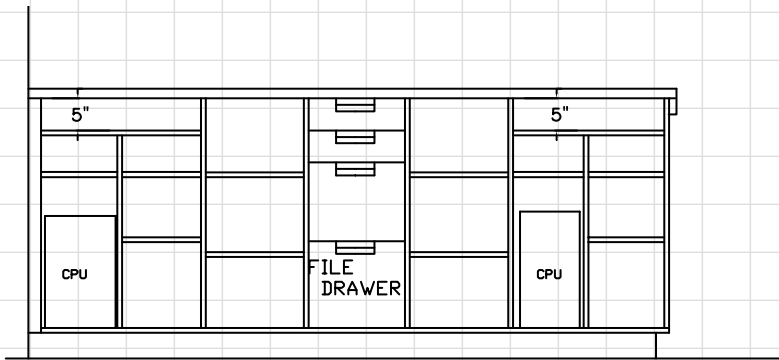

**ELEVATION @ EMPLOYEE SIDE**

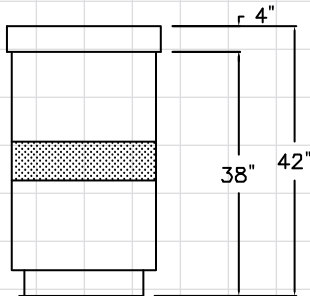
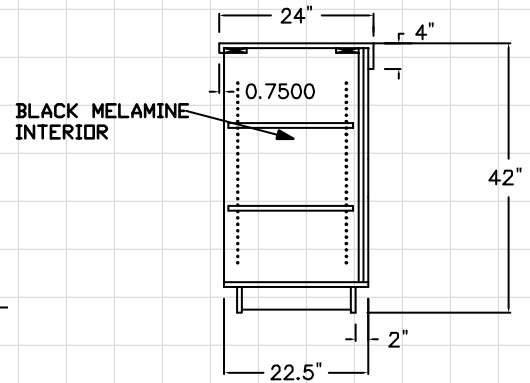

**SIDE ELEVATION**

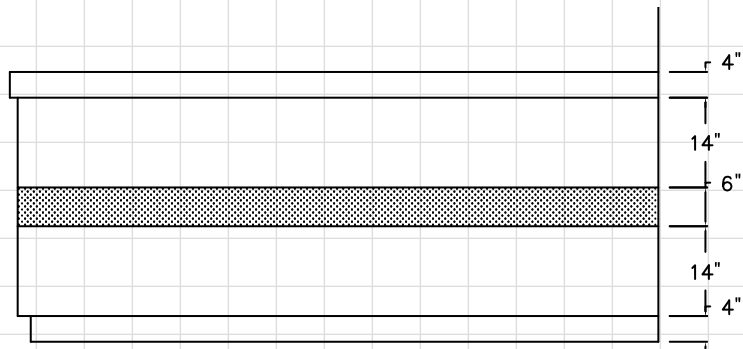

**FRONT ELEVATION**



# SHAPES UNLIMITED <sup>INC</sup>

1735 Nixon Street  
Little Chute, WI 54140

800-811-1385

920-788-5400

Fax 920-788-5453

e-mail: [sales@shapesunlimited.com](mailto:sales@shapesunlimited.com)

[www.shapesunlimited.com](http://www.shapesunlimited.com)

## **Payment Options:**

Full payment must be received prior to ship date and a minimum of 50% deposit is required when order is placed.

Check payments accepted with order-payable to Shapes Unlimited Inc. must also include freight charges. Please call ahead for freight quote.

Established account-terms of 1% 10 net 30 may be obtained if credit references are received and approved prior to order date.

## **Warranties:**

Please read the order acknowledgement carefully. If there is any error in the acknowledgement, notify the factory immediately, lack of such notification is an assumption of the accuracy of this order.

## **Sales Tax:**

Wisconsin customers are responsible to pay respective sales tax, unless a tax exempt certificate is provided.

## **Orders:**

Orders should be confirmed in writing by signing quote or order acknowledgement and faxing back. Shapes Unlimited will not assume any responsibility for order errors, unless written order is received prior to processing.

## **Damaged Shipment:**

We take every precaution to insure safe arrival of your merchandise. If you receive damaged merchandise, please have delivering driver note that on the freight bill at the time of delivery before his departure. Contact Shapes Unlimited immediately and report damage. This must be done before a claim can be filed. Save all packing material and boxes for inspection.

**Do not throw away material until after claim is settled!**

## **Liabilities:**

There are no warranties of any kind, expressed or implied on either the goods or services we offer. Shapes Unlimited makes no claim that the materials or construction methods employed are fit for a particular purpose or use. In no case shall Shapes Unlimited be liable for direct, indirect or consequential damages incurred. All claims of any kind shall be limited to the replacement or purchase price of goods sold.

**Quotes are valid for 30 days and prices are subject to change without notice.**

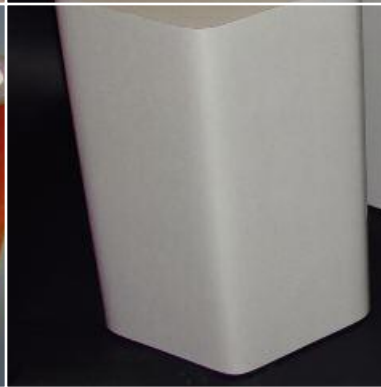
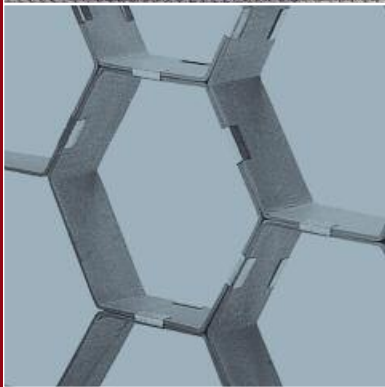

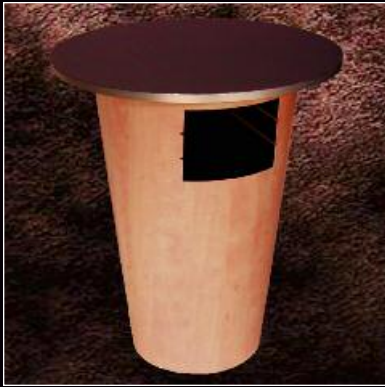

SHAPES UNLIMITED <sup>CO</sup> <sub>INC</sub>

1735 Nixon Street • Little Chute, WI 54140  
800-811-1385 • 920-788-5400 • Fax: 920-788-5453

[www.shapesunlimited.com](http://www.shapesunlimited.com)